

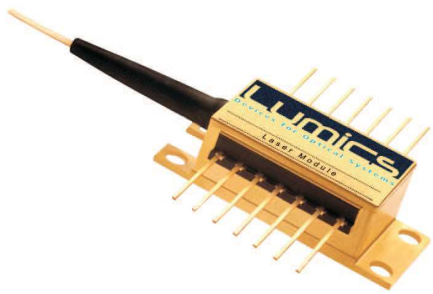

LU1064M300 1064 nm Single Mode Laser Module up to 300 mW c.w. Operating Power



Description:

The Lumics single mode laser module contains an optimized GaAs substrate based quantum well high power laser diode. It has been designed for customer specific applications and is available with special FBG's and fibers. The extremely stringent reliability requirements are achieved through our patent pending innovative technology. This includes careful design, exactly defined manufacturing and extensive testing. The qualification contains a set of optoelectronic, thermal and mechanical tests. Each laser diode module is individually serialized for traceability and is shipped with a specified set of test data.

Features & Functions:

- Single mode pigtail
- Cooled 14pin package
- Telcordia compliant package
- RoHS compliant

Options:

- FBG-options
- Low rise <1 ns
- Narrow and ultranarrow linewidth
- Connector incl. 900µm protection tube

Benefits:

- All laser welded
- Field proven reliability
- Hermetic sealing

Applications:

- Sensor applications
- Analytical instruments
- Pumping and seeding
- Printing

Module Drawing (Dimensions in mm)

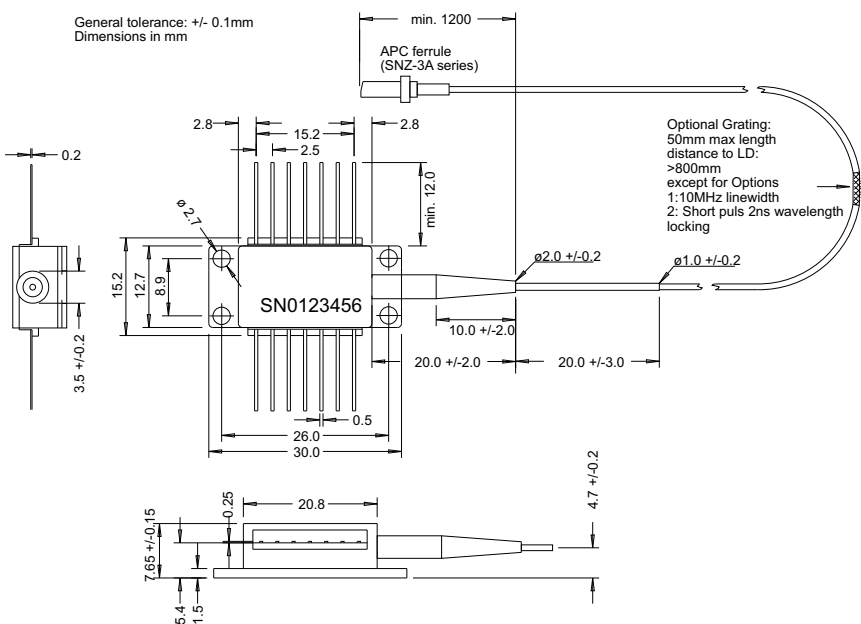

Pin Connections

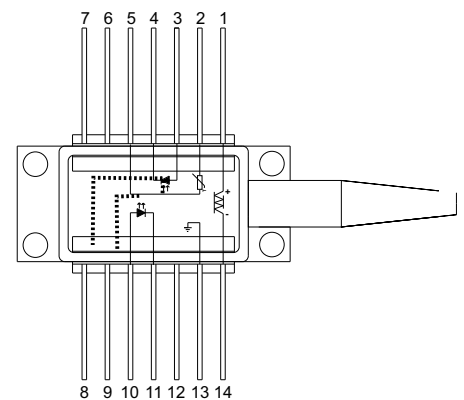

Pin	Function	Pin	Function
1	Cooler (+)	8	(*) LD Cathode (-)
2	Thermistor	9	(*) LD Anode (+)
3	PD Anode (+)	10	LD Anode (+)
4	PD Cathode (-)	11	LD Cathode (-)
5	Thermistor	12	nc
6	nc	13	Case ground
7	nc	14	Cooler (-)

(*) Optional low inductive

We manufacture diode lasers.

Typical laser specifications at 25°C (*) (at 25°C (T_{chip} and T_{case}) and Begin of Life (BOL)):

Parameter	Conditions	Symbol	Min	Typ	Max	Unit
C.w. operating power (1)	c.w.	P _{op}		300		mW
C.w. operating current	c.w.	I _{op}		500		mA
Pulsed operating peak power	< 500ns / duty cycle <5%	P _{op_puls}		1000		mW
Pulsed operating peak current	< 500ns / duty cycle <5%	I _{op_puls}			1.7	A
Rise and fall time (2)				2		nsec
Threshold current		I _{th}		75		mA
Forward voltage	at I _{op}	V _{op}		1.6	1.75	V
Peak wavelength λ _{peak} (3)	at P _{op} , without FBG	λ	1059	1064	1069	nm
Spectral width (FWHM) (3)	at P _{op} , without FBG	Δλ	0.05	multiple peaks, 0.1	<1	nm
Spectral width (FWHM) (4)	at P _{op} , with FBG only	Δλ	0.05	0.08	0.5	nm
Optical power stability	at I _{op} , t = 60 sec	P _{op} / t			0.5	%
Spectral shift with internal temp.	without FBG, internal T _{chip}	Δ / T		0.3		nm/ °C
Spectral shift with temp.	FBG Temp.	Δ / T		0.005	0.012	nm/ °C
Spectral shift with current no FBG	(c.w.)			5		nm/A
Spectral shift with current no FBG	(100ns / duty cycle 1%)			1		nm/A
Side mode suppression (3)	at P _{op} , with FBG			20		dB
Monitor responsivity		R	0.1	1	5	μA/mW
Monitor dark current				5	40	nA
TEC current	chip 25°C, case 70°C	I _{TEC}		1.1		A
TEC voltage	chip 25°C, case 70°C	V _{TEC}		1.9		V
Thermistor resistance	T=25°C	R _{th}	9.5	10	10.5	kOhm
Thermistor B constant		B	3850	3950	4050	K
Steinhart-Hart-Equation coefficients	C ₁ = 1.1292E-03 / C ₂ = 2.3411E-04 / C ₃ = 8.7755E-08					
Large signal modulation bandwidth				200		MHz
Fiber Specifications						
Fiber type	single mode (similar to HI 1060)					

Notes:

- 1) Ensure sufficient protection against high energy back reflection pulses from solid state lasers. High energy back reflection damages the diode (for example stimulated Brillouin scattering). Typical damage threshold for 8ns puls @200KHz is 0.05μJ (this level is not covered under warranty).
- 2) Rise and fall times depend on appropriate driver and can be lower than 1ns with the low inductive version.
- 3) Wavelength is measured in air. Without wavelength stabilisation by a fiber bragg grating (FBG) multiple peaks (side modes) around the average wavelength for a specific current in a range of (1-3) nm are observed. The full width half maximum (FWHM) of those peaks can suddenly narrow or broaden. Side mode suppression counts the first side peaks next to the main peak. A peak is defined by significant lower values left and right to this peak.
- 4) With wavelength stabilisation by a fiber bragg grating (FBG) a single peak for a specific current is observed. The full width half maximum (FWHM) of this single peaks is stable over time as long as it is not disturbed by further back reflection from the outgoing optical path.

General Parameters / Accessories

Parameter	Symbol	Min	Typ	Max	Unit
Storage temp.	T _{max}	-40		85	°C
Operating case temp.	T _{op, case}	-20		70	°C
Operating chip temp.	T _{op, chip}	20		40	°C
Soldering temp. (max. 10sec)		260			°C
LD reverse voltage	VR, max			2	V
Monitor forward current	IF, PD			5	mA
Monitor reverse voltage	VR, PD			20	V
TEC current	ITEC			2.5	A
TEC voltage	VTEC			3.2	V
ESD damage (1)		500		V	
Fiber pigtail bend radius				25	mm

(1) A standard human body model (1.5kOhm, 1000pF) is used for ESD thresholds

Note:

Absolute maximum rating for the laser diode operating current in cw mode may be applied for short period of time only (<10s). Exposure to maximum ratings for extended period of time or exposure above one or more max ratings may cause damage or affect the reliability of the device.

User Safety

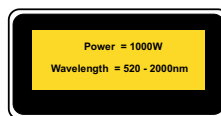

Important Note Read and carefully follow operating manual instructions. Especially, whenever power supply is switched on or off, always disconnect from laser module. See manual for details. Uncontrolled on / off switching may cause spikes and result in fatal device damage. This product is not certified by with IEC 60825-1 or 21CFR1040.10/ 21CFR1040.11 and must comply with the applicable regulations by the Purchaser if sold as laser product.

We manufacture diode lasers.